

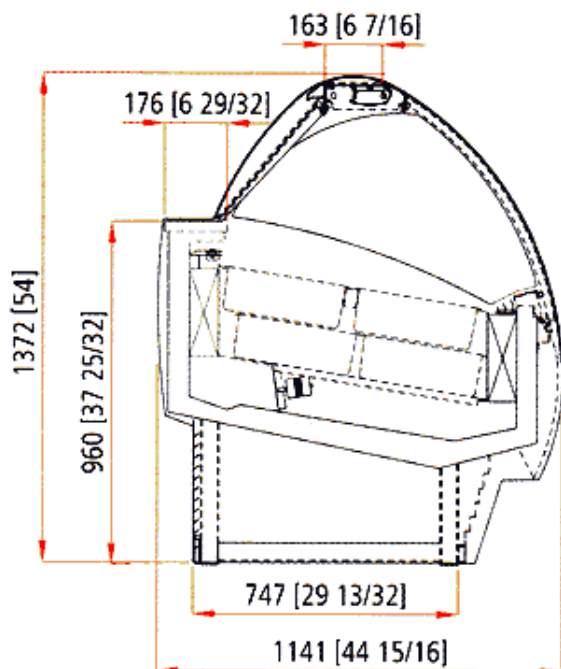

VENTURA

VENTURA XP



	XP 66	XP 99	XP 1212
Rendement	900 W	1800 W	1800 W
Puissance totale	1285 W	2275 W	2540 W
Imax	4,2 A	7,1 A	10,1 A
Poids net	320 Kg	400 Kg	480 Kg

- Vitrine disponible de 12, 18 ou 24 bacs avec réserve.
- Double vitrage chauffé.
- Surface d'exposition inclinée de 9°
- Température de service -18° C à -20° C
- Refroidissement à air
(refroidissement à eau disponible sur commande)
- Alimentation électrique 380/3/50
- Ouverture de la vitre frontale de haut en bas.

VENTURA L

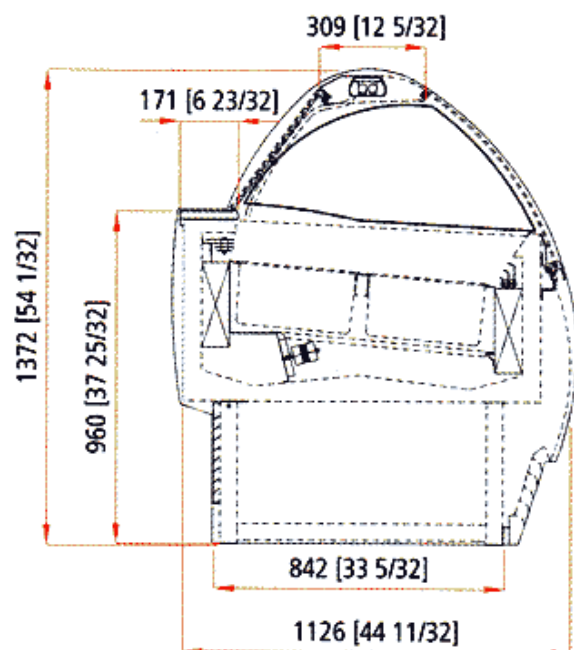

	L 66	L 99	L 1212
Rendement	900 W	1800 W	1800 W
Puissance totale	1020 W	1385 W	1970 W
Imax	3 A	3,8 A	5,7 A
Poids net	320 Kg	380 Kg	480 Kg

- Vitrine disponible de 12, 18 ou 24 bacs sans réserve.
- Simple vitrage chauffé.
- Surface d'exposition inclinée de 4°
- Température de service -18° C à -20° C
- Refroidissement à air
- Alimentation électrique 380/3/50
- Ouverture de la vitre frontale de haut en bas.



VENTURA^L COULEURS DE FINITION					
	BLANC	BLEU	VERT	ROUGE	ORANGE

VENTURA^{XP} COULEURS DE FINITION					
	BLANC	BLEU	VERT	ROUGE	ORANGE
			Possibilité de personnaliser la finition en choisissant parmi les couleurs du système RAL.		
	WENGE	BEIGE			

